

COMPRESSOR

LINEAR

Ac0602



**MOTOR FREE
PISTON SYSTEM**



Airflow & Power Consumption

Specifications

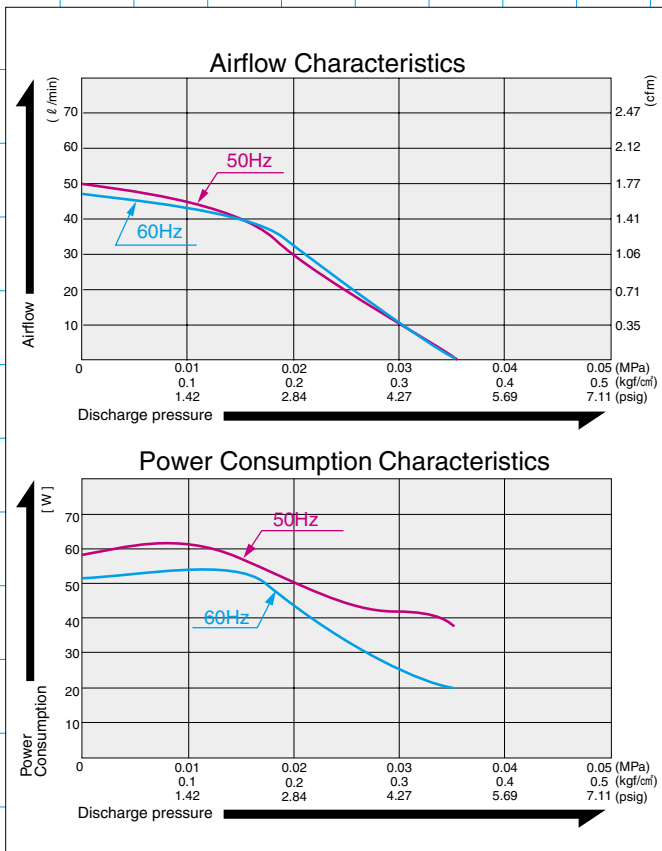

	(SI)	(EURO)	(U.S.A.)
Rated Pressure	0.015 MPa {0.15 kgf/cm ² }	0.15 bar	2.13 psig
Rated Airflow	40 l/min		1.41 cfm
Rated Voltage	115 V AC or 230 V AC		
Maximum Pressure	0.035 MPa {0.35 kgf/cm ² }	0.35 bar	4.98 psig
Power Consumption	52 W or 58 W		
Rated Frequency	60 Hz or 50 Hz		
Life Expectancy	10,000 hours		
Outlet	ISO Rc 1/4 (female threaded)		
Duty Cycle	Continuous		
Coil Insulation Class	E or its equivalent (JETL) or B for UL		
Mounting Dimensions	68 (L) x 84 (W) mm	2-11/16" (L) x 3-5/16" (W)	
Gross Weight	3 kg		6.6 Lbs.
Leadwire Length	250 mm or 350 mm	9-13/16" for 115V	

Please read the page of "How to Use This Catalog" first for correct use of compressors and pumps.

Application Examples

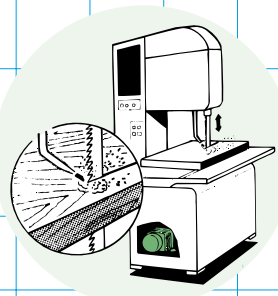

Air Blaster for Bandsaw

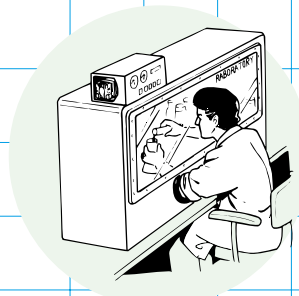

Clean Room Ventilation

Sketch Drawing and Mounting Dimensions Diagram (mm)

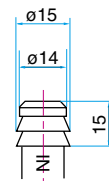
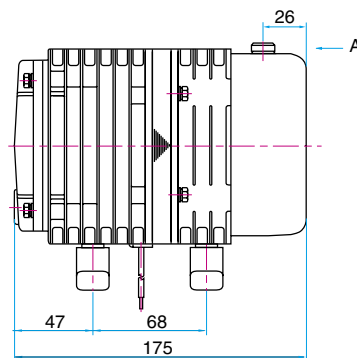
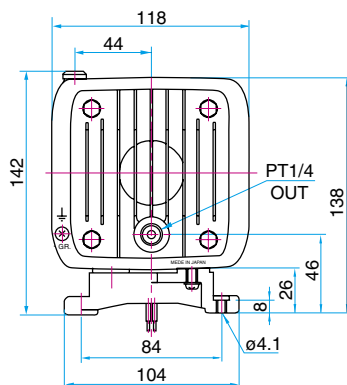

View A